

320 Validate CoS Reading

Message

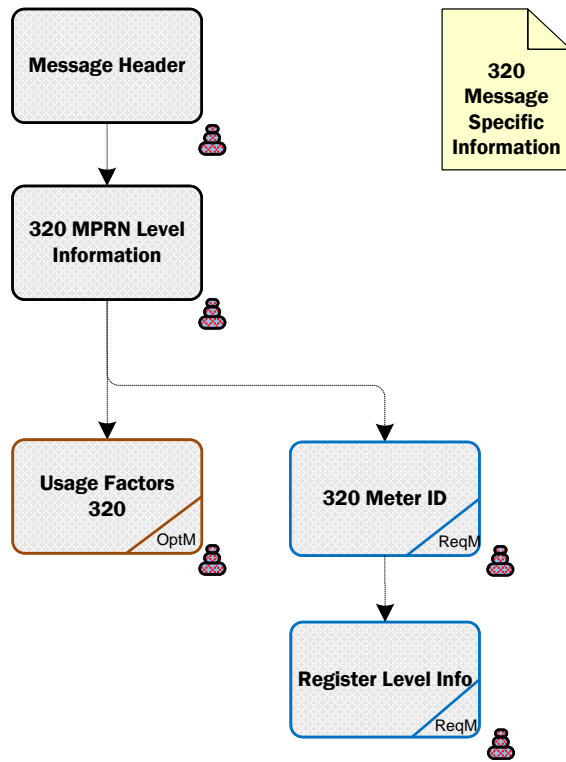

320 Validate CoS Reading

320 Valid Codes
Meter Point Status
E – Energised
Read Reason
26 – Change of Supplier
Read Type
A – An actual reading obtained by ESB Networks
E – An estimate due to no-access or a missing register reading
EF – An estimate due to an implausible reading / No read available
RC – A replacement reading or estimate agreed for use by both Suppliers
CU – A reading provided directly by a customer
SC – A customer reading provided by a Supplier
EP – An estimate due to a planned no-visit
EU – An estimate due to an unplanned no-visit
Please Note
Estimate of Consumption
This is provided for all non MD registers and only at CoS and to the New Supplier only. This value will not necessarily be equal to the EUF for the timeslot.
Optional/Mandatory; Although the following Data Items are optional, note the following caveats:-
Estimated Usage Factor: Provided for the period following the read date

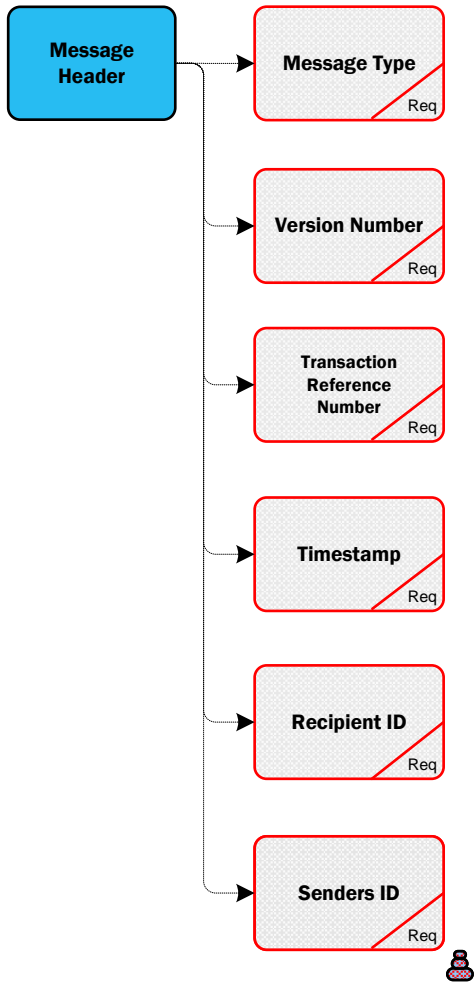

320 MPRN Level Info

MPRN

Req

Meter Configuration Code

Req



Market Participant Business Reference

Opt

Keypad Premises Number

Opt

Networks Reference Number

Req

Load Profile

Req



DUoS Group

Req



Meter Point Status

Req



Read Date

Req

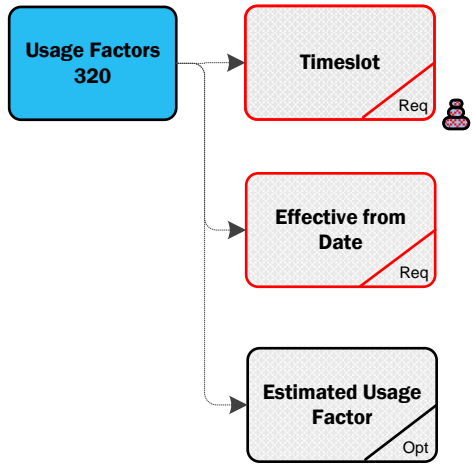

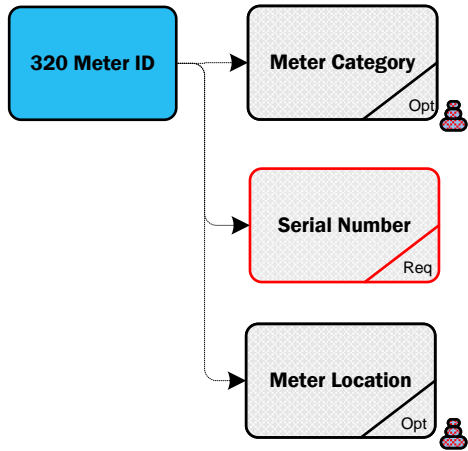

Register Level Information

Meter Register Sequence

Req

Register Type

Req



Timeslot

Req



Pre Decimal Digits

Req

Unit of Measurement

Req



Post Decimal Digits

Req

Meter Multiplier

Req

Estimate of Consumption

Opt

Reading

Req

Read Reason

Req



Read Type

Req



**Senders
ID**

**Click Here for Latest
Senders ID
List**

320 Validate CoS Reading

Code

Load Profile

01 - Urban Domestic Unrestricted

10 - Unmetered - Flat

02 - Urban Domestic Day/Night

11 - Public Lighting Dusk/Dawn

03 - Rural Domestic Unrestricted

12 - Public Lighting Dusk/Midnight

04 - Rural Domestic Day/Night

25 - Urban domestic SST

05 - Non Domestic Unrestricted

27 - Rural domestic SST

06 - Non Domestic Day/Night

29 - Non-domestic SST

07 - MD with LF up to (but not including) 30%

08 - MD with LF greater than or equal to 30% but less than 50%

09 - MD with LF greater than or equal to 50%

Message

MPRN Level Information

Load Profile

320 Validate CoS Reading

Code

DUoS Group

AGU	DG1	Urban Domestic	DG7	MV MD
AMM	DG10	Yes	DG7A	MV MD Autoproducer
CAN	DG2	Rural Domestic	DG7B	MV MD Importing Autoproducer or CHP Producer
CIP	DG3	Public Lighting	DG8	38 kV Looped MD
COL	DG4	Unmetered Supplies	DG8A	38 kV Looped MD Autoproducer
COS	DG5	LV Non-Domestic Non-MD	DG8B	38 kV Looped MD Importing Autoproducer or CHP Producer
CUG	DG5A	LV Non-Domestic Non-MD Autoproducer	DG9	38 kV Tailed MD
DIJ	DG5B	LV Non-Domestic Non-MD Importing Autoproducer or CHP Producer	DG9A	38 kV Tailed MD Autoproducer
DSO	DG6	LV MD	DG9B	38 kV Tailed MD Importing Autoproducer or CHP Producer
IA	DG6A	LV MD Autoproducer	DG10	110kV Distribution
ICD	DG6B	LV MD Importing Autoproducer or CHP Producer	TCON	Transmission Connected

Message

MPRN Level Information

RMDS RETAIL MARKET DESIGN SERVICE

DUoS Group

320 Validate CoS Reading

Code

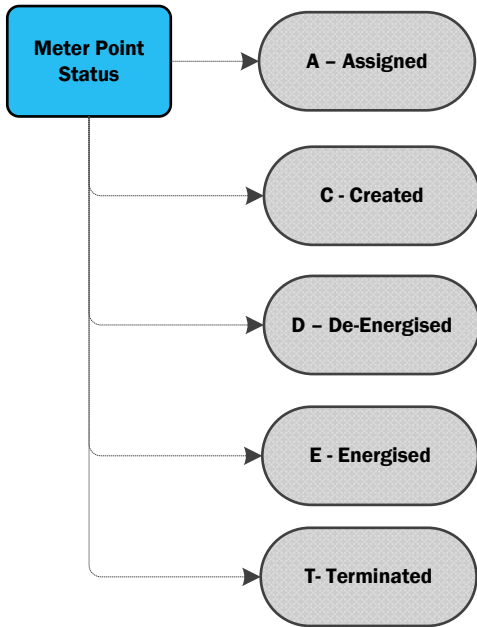

320 Validate CoS Reading

Segment

Meter Configuration Code

MCC01 - 24 Hour	MCC10 - QH2CH_IP	MCC61 - 2x24h	MCC73 - 4x24H+NSH
MCC02 - P/N	MCC11 - QH4CH_IPXP	MCC62 - 2x24h+NSH	MCC74 - 5x24H
MCC03 - 24h+NSH	MCC50 - NONSTN	MCC63 - 2x24h+D	MCC75 - 24H+2xNSH
MCC04 - D/N+W	MCC51 - D/N+NSH	MCC64 - 2x24h+W	MCC76 - 4x24H+W
MCC05 - MDNm/PK	MCC53 - 2 X D/N	MCC65 - 3x24hr	MCC77 - 2x24H+W+NSH
MCC06 - MDNm+Pk	MCC57 - 24h+D	MCC67 - 3x24h+Day	MCC78 - 3x24H+W+NSH
MCC07 - 24H+NSH+W	MCC58 - 24h+D/N	MCC70 - 3x24H+NSH	MCC79 - 5x24H+NSH
MCC08 - 24h+W	MCC59 - 24h+D/N+W	MCC71 - 4x24H	MCC12 - HH1CH_1CR_IP
MCC09 - Unmetered	MCC60 - 24h+D/N+NS	MCC72 - 3x24H+W	MCC16 -SST IMP

Message

MPRN Level Information

Meter Configuration Code

320 Validate CoS Reading

Code

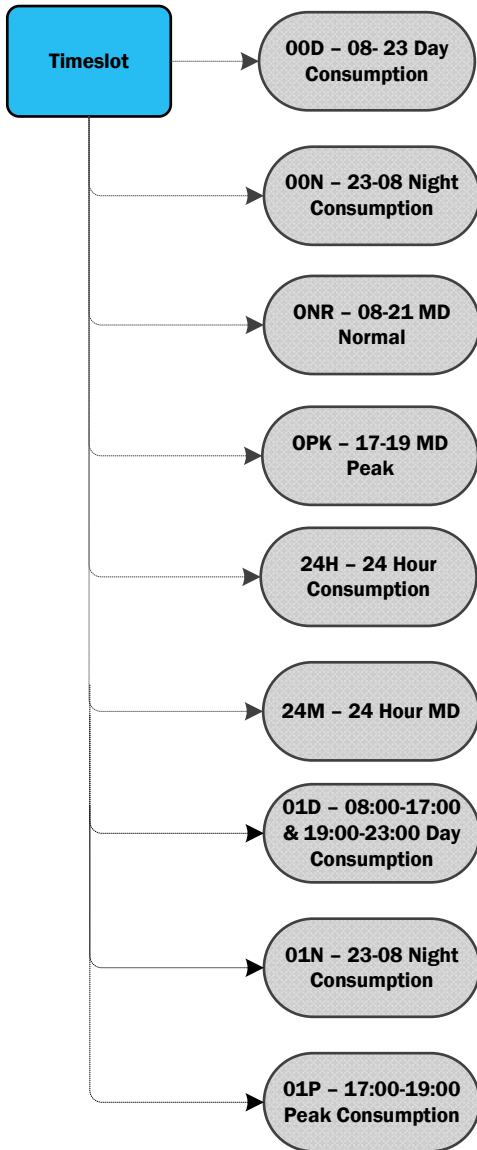

Meter Category

**Click Here for Latest
Meter Category
List**

320 Validate CoS Reading

Segment

Meter Location

01 - Basement	10 - Pumphouse	19 - Annexe
02 - Garage	11 - Scullery/ Pantry/Kitchen	20 - Milking parlour/ Dairy
03 - Hall	12 - Shop	21 - Workshop
04 - Kitchen	13 - Switchroom/ Board	22 - Store
05 - Landing	14 - Under Stairs	23 - Back door
06 - Office	15 - Car Park	24 - Bedroom
07 - Outside box	16 - Pole	25 - Boiler House
08 - Porch	17 - Lobby	26 - Factory
09 - Press	18 - Shed/Outoffice/ Barn	

Message

Meter ID 320

RMDS

RETAIL MARKET DESIGN SERVICE

Meter Location

320 Validate CoS Reading

Code

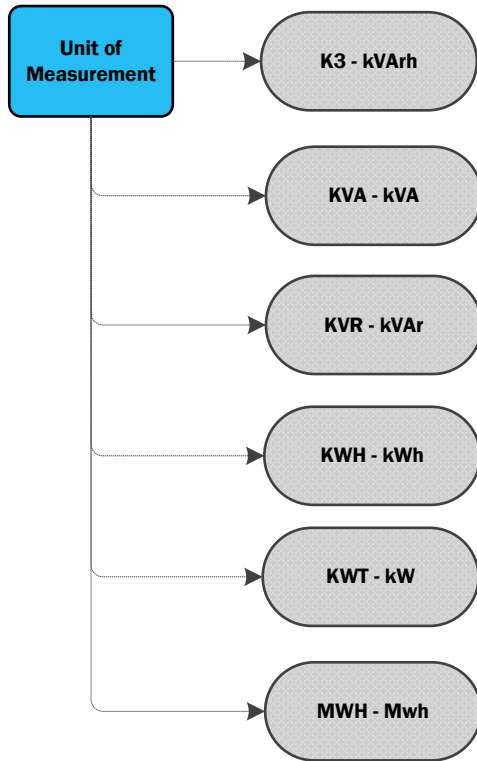

320 Validate CoS Reading

Code

Read Reason

01 - Scheduled

17 - Change of Profile

95 - Not for CoS

02 - Special Read, Chargeable

18 - Energisation

04 - Special Read to resolve dispute

21 - Start Reading (New Register)

09 - Special Read, non chargeable

22 - Closing Reading (Register removed)

10 - Ad-hoc, no chargeable check read

23 - Meter Works Single reading

11 - Start reading after meter re-programming

26 - Change of Supplier

13 - De-Energisation

27 - Change of Legal Entity

14 - Estimate

28 - Closing read before register re-number

16 - Closing read before meter re-programming

29 - Star read after register re-number

Message

Register Level Info

RMDS

RETAIL MARKET DESIGN SERVICE

Read Reason

320 Validate CoS Reading

Code

Read Type

A - Actual

SU - Substitute
(Interval)

CU - Customer
Reading

E - Estimate (No
Access)

ED - Estimate (DUoS
Billing has occurred)

EF - Estimate
(Implausible/ No
Read available)

EP - Estimate (Block
Planned)

EU - Estimate (Block
Unplanned)

RC - Replacement
Read

SC - Supplier
Provided Customer
Reading

Message

Register Level Info

RMDS

RETAIL MARKET DESIGN SERVICE

Read Type

320 Validate CoS Reading

Code

Register Type

01 - 24hr

50 - IMP QH (KW)

02 - Day

51 - IMP QH (kVAr)

03 - Night

52 - EXP QH(KW)

04 - NSH

53 - EXP QH (kVAr)

05 - Wattless

70 - Import HH kW

06 - MD Normal

74 - Import 24hr kWh

07 - MD Peak

78 - Day Off Peak

08 - Cumulative MD Normal

79 - Night Off Peak

09 - Cumulative MD Peak

80 - Peak

Message

Register Level Info

Register Type

320 Validate CoS Reading

Version Which Implemented	Source of Change	Description of Change
10.4	MCR 1155	Message format changed from ARIS to Document format.
10.6	CoBLCR 008 & CoBLCR 011 Non Conformance AIQ 2940	CoBLCR 008 & 011 - Meter Category – Removed table & replaced with link to Meter Category page on RMDS Website. AIQ 2940: The following codes were removed from Consumption on the 320 message: Previous Read Date, Read status & Consumption The following codes were added in their place. Pre-Decimal Digits - Mandatory Post- Decimal Digits - Mandatory Estimate of Consumption
13.0	MCR1159	New Codes added for Load Profile, Meter Configuration Code, Timeslot and Register Type.